

Finite Field Arithmetic for Cryptography

Erkay Savaş and
Çetin Kaya Koç

Abstract

Cryptography is one of the most prominent application areas of the finite field arithmetic. Almost all public-key cryptographic algorithms including the recent algorithms such as elliptic curve and pairing-based cryptography rely heavily on finite field arithmetic, which needs to be performed efficiently to meet the execution speed and design space constraints. These objectives constitute massive challenges that necessitate interdisciplinary research efforts that will render the best algorithms, architectures, implementations, and design practices. This paper aims to provide a concise perspective on designing architectures for efficient finite field arithmetic for usage in cryptography. We present different architectures, methods and techniques for fast execution of cryptographic operations as well as high utilization of resources in the realization of cryptographic algorithms. While it is difficult to have a complete coverage of all related work, this paper aims to reflect the current trends and important implementation issues of finite field arithmetic in the context of cryptography.

© BRAND X PICTURES

1. Introduction

Efficient implementation of cryptographic algorithms has been in the focal point of major research efforts for the last two decades. Different metrics such as execution time (speed), implementation space (silicon area, code size, memory usage, etc.) and power usage/energy consumption are used to quantitatively measure the performance of a design/implementation.

Efficiency can be defined as one of these metrics depending on the application requirements. While execution time is important for applications where latency and throughput is of utmost importance, implementation space is crucial for constrained platforms. Energy and power are also important for the latter case. Since there is almost always a trade-off in execution time and implementation space, faster designs generally require more area.

Efficiency of the design can also be thought as a combined performance metric and is usually measured

Digital Object Identifier 10.1109/MCAS.2010.936785

Cryptographic algorithms utilize arithmetic in finite mathematical structures such as finite multiplicative groups, rings, and finite fields.

using area-time product that shows how effectively the design space is utilized. Related with this, *compactness* of the implementation of a cryptographic algorithm is also an issue attracting increasing attention. A design is *compact* if its implementation space is small compared to its execution speed. Another criteria is the design's versatility. A design is *versatile* if it can be used in diverse set cryptographic operations. *Versatility* and compactness of a design assist improve the {area \times time} metric.

Majority of cryptographic algorithms utilize arithmetic in finite mathematical structures such as finite multiplicative groups, rings, and finite fields. Having a complete set of arithmetic operations, finite fields feature a superset of operations of rings and multiplicative groups. While multiplicative groups have only one defined operation and rings do not have multiplicative inversion defined for its every element, finite fields feature addition/subtraction, multiplication/division, and both multiplicative and additive inversion operations. Since overwhelming percentage of execution time of cryptographic algorithms is spent on these arithmetic operations, efficient implementation of these operations determines the efficiency of the overall cryptographic system.

The basic arithmetic operations (i.e. addition, multiplication, and inversion) in finite fields, $GF(q)$, where $q = p^k$ and p is a prime integer, are heavily used in many cryptographic algorithms such as RSA algorithm, Diffie-Hellman key exchange algorithm [13], the US federal Digital Signature Standard [36], elliptic curve cryptography [27, 33], and also recently pairing-based cryptography [3, 48]. Most popular finite fields that are commonly used in cryptographic applications due to elliptic curve based schemes are prime fields $GF(p)$ and binary extension fields $GF(2^n)$. Recently, pairing-based cryptography based on bilinear pairings over elliptic curve points stimulated a significant level of interest in the arithmetic of ternary extension fields, $GF(3^n)$.

The aforementioned three popular finite fields feature dissimilar mathematical structures. Therefore, it is important to design algorithms and architectures that will exploit the specific properties of the underlying field to give the best performance for the chosen efficiency metric. On the other hand, elements of different finite fields are represented using similar data structures inside the digital

circuits and computers. Furthermore, similarity of algorithms for basic arithmetic operations in these fields allow diverse utilization of the functional units in the design.

A paramount example of diverse utilization of the functional units is the unified module design [47]. For example, the steps of the original Montgomery multiplication algorithm [35], which is one of the most efficient methods for multiplication in finite fields and rings, $GF(p)$ and Z_n , slightly differ from those of the Montgomery multiplication algorithm for binary extension fields, $GF(2^n)$, given in [28]. In addition, it is almost straightforward to extend the Montgomery multiplication algorithm for ternary extension fields, $GF(3^n)$, by essentially keeping the steps of the algorithm intact. Similarly, addition or inversion operations can be performed using similar algorithms that can be realized together in the same digital circuit. To summarize, an arithmetic module which is versatile in the sense that it can be adjusted to operate in more than one of the three fields is feasible, provided that this extra functionality does not lead to an excessive increase in area and dramatic decrease in speed. One important result from the recent research is that a *unified* module that is capable of performing arithmetic in more than one field in the same, unified datapath brings about many advantages, one of which is the improved {area \times time} product.

Exploiting the same set of functional units in the computations of a variety of cryptographic operations is essential in designing efficient and compact architectures and implementations. For instance, any field operation can be performed using only adder circuits. Subtraction can easily be transformed into addition (the two are identical in finite fields of characteristic two), multiplication can be seen as repeated addition, efficient multiplicative inversion algorithms feature only addition, subtraction and shift operations. Therefore, an architecture for finite field operations can be designed around a set of fast adder circuits¹.

In this paper, we provide a survey of algorithms, architectures, and design practices that allow fast, efficient and compact implementations of finite field arithmetic. We target three categories of cryptographic algorithms:

- Cryptographic algorithms that use finite multiplicative groups and rings such as RSA,
- Elliptic curve cryptography,
- Pairing-based cryptography.

Erkay Savaş (erkays@sabanciuniv.edu) is with Sabanci University and Çetin Kaya Koç (koc@cs.ucsb.edu) is with Istanbul Şehir University and the University of California, Santa Barbara.

¹Carry-Free adders that eliminate the carry-propagation are the most popular adders in cryptographic applications.

The key point to an efficient finite field arithmetic is to design fast and light-weight adder circuits.

We present algorithms for arithmetic operations that can be generically applied. For example, we focus on the usage of the polynomial base for binary, ternary and general extension fields. Special polynomials (e.g. trinomials, pentanomials) that can be beneficial in field multiplication are not emphasized here since they may not be generic; except for the general extension fields where computations can be made considerably faster when specific irreducible polynomials are used.

2. Fundamentals of Finite Fields and Their Arithmetic

The elements of the prime finite field $GF(p)$ are the integers in the set $\{0, 1, 2, \dots, p-1\}$ where p is an odd prime. The addition and multiplication operations in $GF(p)$ are modular operations performed in two steps:

- 1) regular integer addition or multiplication, and
- 2) reduction by the prime modulus p if the result of the first step is greater than or equal to the modulus.

The elements of the binary extension field $GF(2^n)$ can be represented as binary polynomials of degree less than n if polynomial basis representation is used. Analogous to the odd prime used in $GF(p)$, a binary irreducible polynomial of degree n is used to construct $GF(2^n)$. The addition in $GF(2^n)$ is modulo-2 addition of corresponding coefficients of two polynomials. Since it is basically a polynomial addition there is no carry propagation and the degree of the resulting polynomial cannot exceed $n-1$. On the other hand, multiplication in $GF(2^n)$ is more complicated and sometimes it is beneficial to use other types of representation techniques than standard polynomial basis such as Gaussian normal basis [18]. Here, we always use polynomial basis for $GF(2^n)$ because of its suitability to the proposed design principles.

Polynomial basis representation of $GF(2^n)$ is determined by an irreducible binary polynomial $p(x)$ of degree n . Given $p(x)$, all the binary polynomials of degree less than n , which has the form $A(x) = a_{n-1}x^{n-1} + \dots + a_1x + a_0$, are the elements of $GF(2^n)$. Multiplication in $GF(2^n)$, similar to multiplication in $GF(p)$, is performed in two steps:

- 1) polynomial multiplication followed by
- 2) a polynomial division of the result from Step 1 by the irreducible polynomial $p(x)$.

Similar to binary extension fields, the elements of ternary extension fields $GF(3^n)$ can be represented as (ternary) polynomials of degree at most $n-1$, whose coefficients are from the base field $GF(3)$. In order to utilize polynomial basis for ternary arithmetic, an irreducible

ternary polynomial $p(x)$ of degree n is needed. The addition operation in $GF(3^n)$ is polynomial addition where the corresponding coefficients of two ternary polynomials are added modulo-3 and there is no carry propagation. The multiplication is also done in two steps: a polynomial multiplication followed by reduction by the irreducible ternary polynomial $p(x)$ of the field.

3. Compact Architectures for Addition and Subtraction

The most fundamental arithmetic operation in finite fields and rings, on which all other arithmetic operations are based, is the addition operation. The key point to an efficient finite field arithmetic is to design fast and light-weight adder circuits. In many cryptographic applications in order to balance the speed and area efficiency, adders utilizing redundant representation are preferred. The most basic form of redundant representation is the carry-save form in which an integer is represented as the sum of two other integers, namely $x = x_c + x_s$ where x_c and x_s are known as carry and sum parts of the integer, respectively. The addition operation with carry-save form can be performed using full-adders which have three binary inputs and two binary outputs. Full-adders connected to each other can perform addition where one of the operands are in redundant form while the other in non-redundant form. For n -bit operands, the carry-save adder will need n full adders.

It is possible to perform both $GF(p)$ and $GF(2^n)$ addition operation using so-called dual-field adder (DFA) [47], which is illustrated in Figure 1. DFA shown in Figure 1 is basically a full-adder equipped with the capability of performing bit addition both with and without carry. It has an input denoted as **fsel** that provides this functionality. When **fsel** = 1, the dual-adder circuit performs bit-wise addition with carry which enables the circuit to operate in $GF(p)$ -mode. When **fsel** = 0, on the other hand, the output C_{out} is forced to 0 regardless of the values of the inputs. Consequently, the output **S** produces the result of modulo-2 addition of three binary input values. At most only two of the three binary input values of DFA can have nonzero values in $GF(2^n)$ -mode.

An important aspect of designing a DFA is not to increase the critical path delay (CPD) of the circuit, which otherwise would have a negative effect in the maximum applicable clock frequency. However, a small amount of overhead in area can be accommodated. Gate level realization of DFA shown in Figure 1 clearly demonstrates

that there is no increase in the CPD since the two XOR gates dominate the CPD as in the case of a regular full adder. Area differs slightly due to one extra input, i.e. *fsel* and additional gates that are used to suppress the carry out, C_{out} , in $GF(2^n)$ -mode. However, this increase in area is very small, therefore tolerable, compared to the case where we have two separate adders for $GF(p)$ and $GF(2^n)$ which would incur much more overhead in area.

As described above, 3×2 adder arrays in carry-save adders are in many cases sufficient since addition operation is mostly needed in multiplications where one of the operands is always in non-redundant form as in [51]. In this case, the carry-save form is only used for partial product during the multiplication and the result of the multiplication has to be converted to non-redundant form using a carry-propagation adder after the multiplication is completed. However, when the two operands are both in carry-save redundant form, then 3×2 adder arrays cannot be used. Instead, 4×2 adder arrays are needed to operate on operands that are in redundant form. Using 4×2 adder arrays eliminate the need for an immediate conversion after multiplication, which is especially useful in elliptic curve cryptography where there are many addition and subtraction operations in between multiplication operations.

Classical carry-save redundant representation method has one major drawback due to the difficulty of performing subtraction operation. When two's complement representation is used to facilitate the representation of negative numbers as well as subtraction operation, the carry-save representation poses certain difficulties. For example, during the subtraction of two's complement operands, a carry overflow indicate whether the result is negative or positive. Since there can be a hidden carry overflow in carry-save representation, computationally intensive operations may be needed to determine the sign of the result, which in turn incurs significant increase in CPD and area.

Avizienis [1] proposed the redundant signed digit (RSD) representation to overcome this difficulty. Arithmetic in the RSD representation is almost identical to carry-save arithmetic. An integer is still represented by two positive integers; however, this time the integer is now represented as the difference (as opposed to *the sum* in carry-save representation) of two other integers. An integer x , therefore, is represented by x^+ and x^- , where $x = x^+ - x^-$. As can easily be deduced from the definition of RSD, there is no need for two's

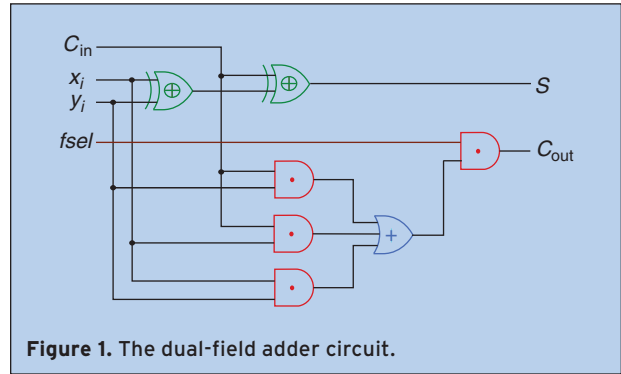

Figure 1. The dual-field adder circuit.

complement representation to handle negative numbers and subtraction operation. The RSD is, thus, a more natural representation when both addition and subtraction operations need to be supported. This is indeed the case in elliptic curve cryptography and Montgomery multiplication and inversion algorithms. An additional benefit of RSD representation is the fact that the comparison operation in $GF(p)$ -mode is now possible and efficient. Integer comparison in $GF(p)$ -mode can be performed utilizing a subtraction operation. After subtracting one integer from the other, a sign test can be performed directly by checking the first nonzero bit in significant positions of the result. This is in general an easy method that can be implemented by masking the most significant bits to determine which number is greater.

Realization of RSD arithmetic is very similar to carry-save arithmetic. RSD arithmetic needs generalized full adders which are shown in Figure 2. As observable from Figure 2, GFA-0 is a conventional full adder. From the realization perspective, GFA-1, GFA-2 and GFA-3 are equivalent to GFA-0 realization in ASIC and thus there is no associated overhead in either CPD or area.

The addition of two n -bit RSD integers, x and y , $z = x + y$, can be done by connecting two layers of GFAs of types 1 and 2 as shown in Figure 3. An additional circuitry is needed to force the digit instances of (1, 1) to (0, 0) since $1 - 1 = 0$. Subtraction of two n -bit integers,

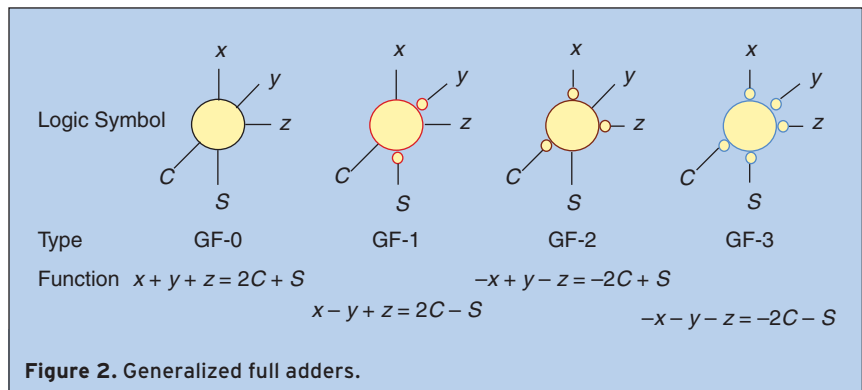

Figure 2. Generalized full adders.

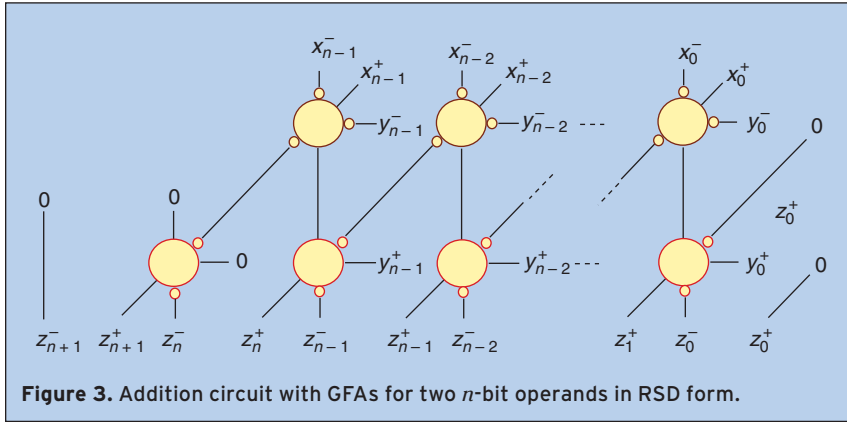

Figure 3. Addition circuit with GFAs for two n -bit operands in RSD form.

$t = x - y$ can be realized using the same addition circuit in Figure 3 by swapping y^+ and y^- . The adder (or subtracter) circuit which is originally designed for $GF(p)$ arithmetic can easily be converted into a dual-field adder (or subtracter) by forcing the carry output of each GFA into 0 in $GF(2^n)$ -mode.

Another side benefit of RSD representation and associated adder structures is their suitability to a fully unified arithmetic that incorporates addition/subtraction in three major finite fields, namely $GF(p)$, $GF(2^n)$ and $GF(3^n)$. Below is the RSD representation of elements of these three fields:

- **Prime field $GF(p)$:** Elements of prime fields can be represented as integers in binary form. Assuming that the digits are signed, the values that digits have and their corresponding representations are $\{0, 1, -1\}$ and $\{(0, 0), (1, 0), (0, 1)\}$.
- **Binary extension field $GF(2^n)$:** A common practice is to consider elements of binary extension field as polynomials with coefficients from $GF(2)$. This allows to represent $GF(2^n)$ elements by simply arranging the coefficients of the polynomial into a binary string. A digit in $GF(2^n)$ -mode can take the values of 1 and 0, which can be represented as $\{(0, 0), (1, 0)\}$.
- **Ternary extension field $GF(3^n)$:** Elements of ternary extension fields can be considered as polynomials whose coefficients are from $GF(3)$. Thus, each coefficient can take the values $-2, -1, -, 1, 2$. The digit values -2 and 2 are congruent to 1 and -1 modulo 3, respectively. Therefore, the RSD representations for possible coefficient values of 0, 1, and -1 are $\{(0, 0), (1, 0), (0, 1)\}$.

A unified adder that operates in three fields can be derived from the addition circuit in Figure 3. When compared to $GF(p)$ -only adder, the unified adder circuit has only marginally higher CPD while the overhead in area can be higher. However, the area cost of three non-unified adders implemented in three separate circuits far

outweighs this overhead in the unified design as shown in [39].

4. Multiplication

In this section, we firstly provide efficient architectures for Montgomery multiplication algorithm. These architectures are suitable for ASIC as well as FPGA implementations. We then introduce the unified Montgomery multiplication algorithm in [47], which operates only in $GF(p)$ and $GF(2^n)$. We then present a dual-radix unified multiplier

in [46] where the multiplier calculates faster in $GF(2^n)$ -mode than in $GF(p)$ -mode. We finally discuss the support in the unified multiplier for multiplication in $GF(3^n)$.

4.1. Montgomery Multiplication Algorithm

In [35], Montgomery described a modular multiplication method which proved to be very efficient in both hardware and software implementations. An obvious advantage of the method is that it replaces division operations with simple shift operations. The method adds multiples of the modulus rather than subtracting it from the partial result. And unlike the subtraction of modulus in the regular modular multiplication which can be performed after all the digits of the multiplicand are processed for a given multiplier digit, the addition operation can start immediately after the least significant digit of the multiplicand is processed. Especially the second feature accounts for the inherent concurrency in the algorithm. Refer to [35, 14, 29] for detailed explanation of the algorithm.

Given two integers a and b , and a prime modulus p , the Montgomery multiplication algorithm computes $\bar{c} = \mathbf{MonMult}(a, b) = a \cdot b \cdot R^{-1} \pmod{p}$ where $R = 2^n$ usually and $a, b < p < R$ and p is an n -bit prime number. The Montgomery multiplication does not directly compute $c = a \cdot b \pmod{p}$, therefore certain transformation operations must be applied to the operands a and b before the multiplication and to the intermediate result \bar{c} in order to obtain the final result c . These transformations are applied as in the following example:

$$\begin{aligned} \bar{a} &= \mathbf{MonMult}(a, R^2) = a \cdot R^2 \cdot R^{-1} \pmod{p} = a \cdot R \pmod{p}, \\ \bar{b} &= \mathbf{MonMult}(b, R^2) = b \cdot R^2 \cdot R^{-1} \pmod{p} = b \cdot R \pmod{p}, \\ c &= \mathbf{MonMult}(\bar{c}, 1) = c \cdot R \cdot R^{-1} \pmod{p} = c \pmod{p}. \end{aligned}$$

Provided that $R^2 \pmod{p}$ is precomputed and saved, we need only a single **MonMult** operation to carry out each of these transformations. However, because of these transformation operations, performing a single modular multiplication using **MonMult** might not be advantageous

Advantage of Montgomery arithmetic is in applications requiring multiplication-intensive calculations such as modular exponentiation and elliptic curve point operations.

even though there is an attempt to make it efficient for a few modular multiplications by eliminating the need for these transformations [37]. Its advantage, on the other hand, becomes obvious in applications requiring multiplication-intensive calculations such as modular exponentiation, elliptic curve point operations, and pairing calculations over elliptic curve points.

The Montgomery multiplication algorithm with radix- 2^k for $GF(p)$ can be given as in the following:

Algorithm A

Input: $a, b \in [1, p-1]$, p , and m
 Output: $c \in [1, p-1]$
 Step 1: $c := 0$
 Step 2: for $i = 0$ to $m-1$
 Step 3: $q := (c_0 + a_i \cdot b_0) \cdot (p'_0) \pmod{2^k}$
 Step 4: $c := (c + a_i \cdot b + q \cdot p) / 2^k$

where $p'_0 = 2^k - p^{-1} \pmod{2^k}$. In the algorithm, the multiplier a is written with base (radix)- 2^k as an array of digits a_i so that $a = \sum_{i=0}^{m-1} a_i \cdot 2^{ki}$, where m is the number of digits in a and $m = \lceil n/k \rceil$. In Step 4, the multiplicand b , the modulus p , and the partial result c enter the computations as full-precision integers. However, in the real implementations b , p , and c can be treated as multi-word integers in order to design a scalable multiplier and in each clock cycle one word of these values will be processed. One may also consider this representation as writing the multiplicand, the modulus and the partial result with digits $b^{(j)}$, $p^{(j)}$, and $c^{(j)}$ of w bits, so that $b = \sum_{j=0}^{e-1} b^{(j)} \cdot 2^{wj}$, $p = \sum_{j=0}^{e-1} p^{(j)} \cdot 2^{wj}$, and $c = \sum_{j=0}^{e-1} c^{(j)} \cdot 2^{wj}$ where $e = \lceil n/w \rceil$. Note that the base- 2^w used to represent b , p , and c in Step 4 is different from the radix- 2^k used to represent the multiplier digit a_i in Step 3 and 4. Note also that q , c_0 , b_0 , and p'_0 are all k -bit integers.

In order to avoid a possible confusion due to the usage of two different bases, we use the term *word* refer the digits of b , p and c when implementing Step 4, and use the term *digit* exclusively for the multiplier a , and for b_0 , p'_0 , and c_0 in Step 3 when they are in the same equation with the digits of a . Digits can be easily distinguished by the subscript notation (e.g. a_i or b_0) from superscript notation of word (e.g. $b^{(j)}$). We will also use the notation $x_{i,j}$ to denote the j th bit in the i th digit of x . The notation $c_{0 \dots k}^{(j)}$ represents k least significant bits of the word $c^{(j)}$. In addition, the radix of the multiplier architecture is determined by the base used to represent the multiplier a .

The Montgomery multiplication algorithm for $GF(2^n)$ is given below:

Algorithm B

Input: $a(x)$, $b(x)$, $p(x)$, and m
 Output: $c(x)$
 Step 1: $c(x) := 0$
 Step 2: for $i = 0$ to $m-1$
 Step 3: $q(x) := (c_0(x) + a_i(x) \cdot b_0(x)) \cdot p'_0(x) \pmod{x^k}$
 Step 4: $c(x) := (c(x) + a_i(x) \cdot c(x) + q(x) \cdot p(x)) / x^k$

where $p'_0(x) = p_0^{-1}(x) \pmod{x^k}$. As one easily observes, the two algorithms are almost identical except that the addition operation in $GF(p)$ becomes a bitwise modulo-2 addition in $GF(2^n)$. Although the operands are integers in the former algorithm and binary polynomials in the latter, the representations of both are identical in digital systems. Note that in Algorithm A, there must be an extra reduction step at the end to reduce the result into the desired range if it is greater than the modulus. On the other hand, this step is not an essential part of the algorithm and there are simple conditions that can be added to the algorithm in order to eliminate it [55, 17], hence we intentionally exclude it from the algorithm definitions.

One can also observe that the computations performed in Step 3 are of different nature in two algorithms and depending on the magnitude of the radix used, the part of the circuit in charge of implementing them might become very complicated. However, one can easily demonstrate that these computations can be performed in a unified circuitry for small radices.

From this point on, we will only use the notation introduced in Algorithm A for both $GF(p)$ and $GF(2^n)$ and polynomial notation is only used when it is necessary. Operations will be deduced from the mode ($GF(p)$ or $GF(2^n)$) in which the module is operated.

4.1.1. Processing Unit

In this section, we explain the design details of the processing unit (PU) with radix- 2^k , which is basically responsible for performing Step 3 and Step 4 of Algorithm A:

Step 3: $q := (c_0 + a_i \cdot b_0) \cdot (p'_0) \pmod{2^k}$
 Step 4: $c := (c + a_i \cdot b + q \cdot p) / 2^k$.

In Figure 4 the execution graph of the Montgomery multiplication algorithm and dependencies between

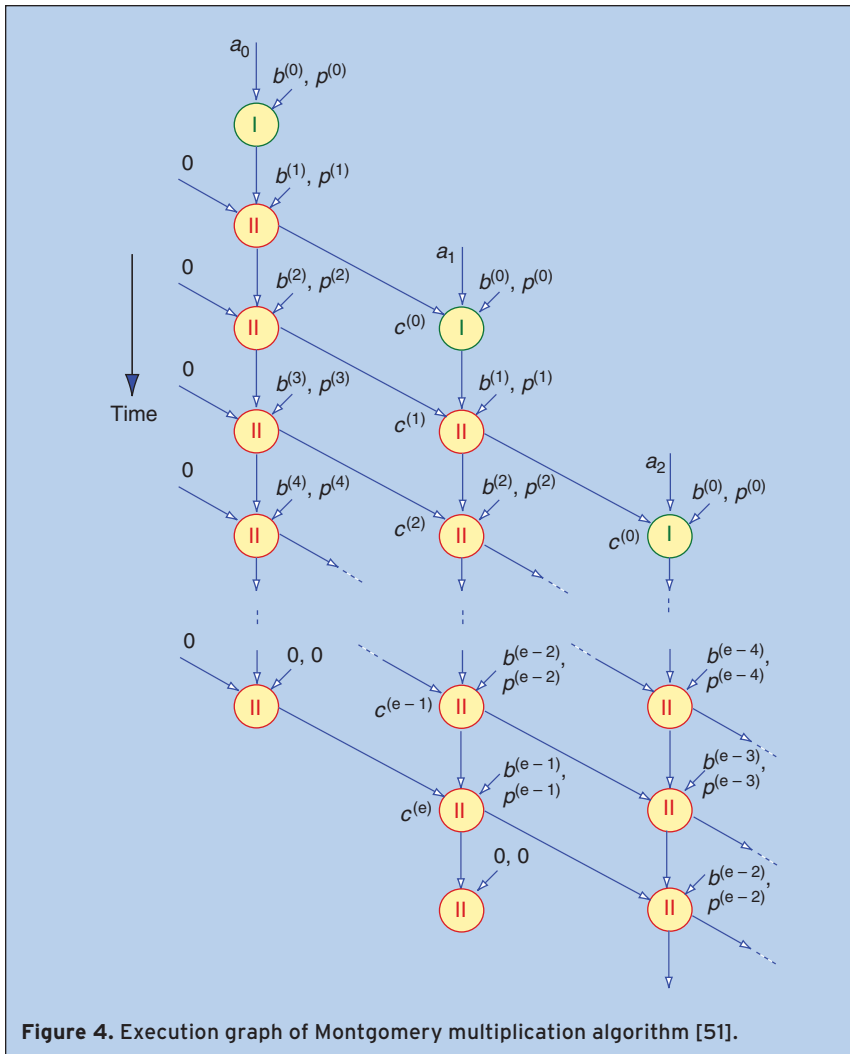

Figure 4. Execution graph of Montgomery multiplication algorithm [51].

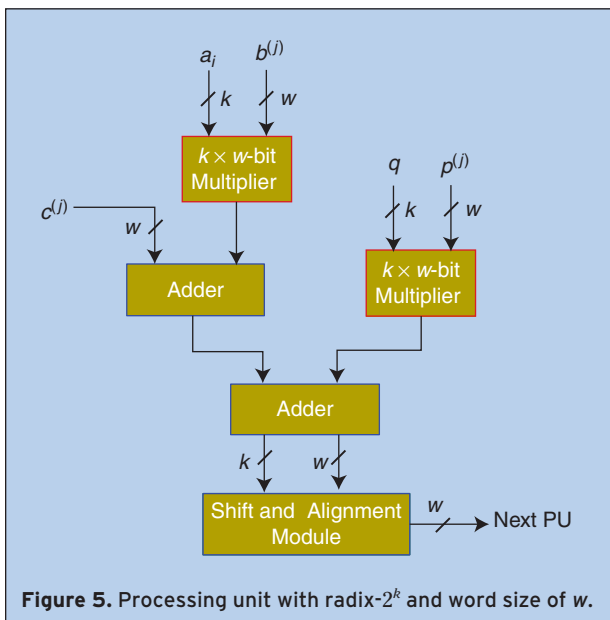

Figure 5. Processing unit with radix- 2^k and word size of w .

the operations are illustrated. Type I circle in the graph represents the operations in Step 3 and Step 4 for the least significant words of b and p without the right shift operation. Type II circle represents Step 4 for the current words of b and p without the right shift operation and the shift operation for the previous words of b and p .

Each column in the dependency graph represents the computation which can be undertaken by a module which we call processing unit (PU) for one digit of the multiplicand a . Each PU scans every word of the modulus p and the multiplicand b . Each circle represents the operations for one word of p , b and c . The time advances from top to bottom.

Figure 5 illustrates the architecture of a processing unit (PU). Two $k \times w$ multipliers compute $a_i \cdot b$ and $q \cdot p$, respectively, where a_i and q are k -bit digits. Note that a PU processes c , b , and a one word at a time. The *shift and alignment module* shifts the previous word of the partial result c by k -bit to the right and fills the leftmost k -bits of the result with the least significant k -bit of the current word of

the partial result c . The circuit for Step 3 is not shown in Figure 5.

In FPGA implementations, the digits of the multiplier and the words of the multiplicand can be of the same length to take advantage of the fast hardwired multipliers [38]. On the other hand, in ASIC implementations where the high radix multipliers are expensive, the radix for the multiplier is usually chosen as a small number. When radix is relatively a small number, the multipliers in Figure 5 becomes simple circuits [53, 52, 47]. For unified implementations, both the multipliers and adders are designed to operate in both prime and binary extension fields. For this, the partial result is kept in carry-save form in $GF(p)$ mode.

The multiplier architecture consists of one or (generally) more processing units (PU), identical to the one shown in Figure 5, organized in a pipeline. An example of pipeline organization with t PUs is shown in Figure 6. Each PU takes a digit (k -bits) from the multiplier a , the size of which depends on the radix, and operates on the

words of b , c and p successively starting from the least significant words. Starting from the second cycle it generates one word of partial result each cycle which is communicated to the next PU. After $e + 1$ clock cycles, where e is the number of words in the modulus (i.e. $e = \lceil n/w \rceil$), a PU finishes its portion of work and becomes free for further computation. When the last PU in the pipeline starts generating the partial results, the control circuitry checks if the first PU is available. If the first PU is still working on an earlier computation, the results from the last PU should be stored in a buffer until the first PU becomes available again. Refer to [51] for more information about the length of the buffer to store the partial results when there is no available PU in the pipeline.

A redundant representation (e.g. carry-save) is used for the partial result in the architecture to speedup the addition operations. Thus, for the partial result we can write $c = cc + cs$, where cc and cs stand for the carry and sum part of the partial result, respectively. In addition, one must note that the length of the register for partial result, c in Figure 6 is twice wider than the other registers.

The proposed architecture allows designs with different word lengths and pipeline organizations for different values of operand precision. In addition, the area can be treated as a design constraint. Thus, one can adjust the design to the given area, and choose appropriate values for the word length and the number of pipeline stages, in accordance. For efficient multiplication architectures and high utilization of hardware resources for FPGA implementations, one can refer to [38].

The propagation delay of PU is independent of word size w when w is relatively small (increases only slightly for larger values of w due to carry-free arithmetic), and thus we assume that the clock cycle is the same for all word sizes of practical interest. The area used by registers for partial sum, operands and modulus does not change with the word or digit sizes.

The proposed scheme yields the worst performance for the case $w = m$, since some extra cycles are introduced by PU in order to allow word-serial computation, when compared to other full-precision conventional designs. On the other hand, using many pipeline stages with small word size values brings about no advantage after certain point resulting in poor utilization. Therefore, the performance evaluation reduces into finding an optimum configuration for given constraints.

ASIC standard cell realizations of both unified and non-unified ($GF(p)$ -only) multipliers demonstrate that area overhead of the unified multiplier is only 2.75% and that there is no overhead in critical path delay [47]. Therefore, the saving in the area is significant when the unified design is compared to a hypothetical architecture that has two separate datapath for $GF(p)$ and $GF(2^n)$

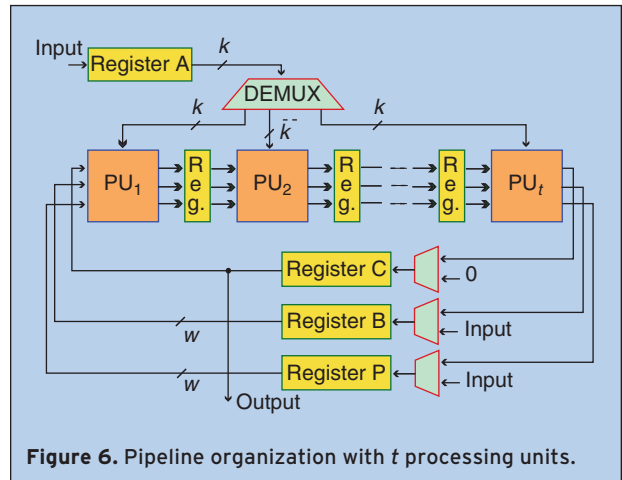

Figure 6. Pipeline organization with t processing units.

multipliers. Furthermore, this saving in area does not bring about a penalty in time performance, therefore improvement in area is identical to the improvement in metric of $\{\text{area} \times \text{time}\}$.

4.2. Dual-Radix Multiplier

The original unified multiplier in [47] uses radix-2 design and offers an equal performance for both $GF(p)$ and $GF(2^n)$ of the same precision in terms of clock count. For this very reason, however, the original design is not optimized since it does not take advantage of using $GF(2^n)$, which is, in general, more efficient than $GF(p)$ in hardware implementations. Our first observation is that this situation can be remedied by putting to use the part of the circuitry which is underutilized in $GF(2^n)$ mode. This allows us to run the multiplier module in higher radix values for $GF(2^n)$ than those for $GF(p)$ at the expense of extra gates without significantly increasing the signal propagation time.

In this section, we present the radix-(2, 4) multiplier architecture introduced in [46], where the multiplier uses radix-2 in $GF(p)$ -mode while it uses radix-4 in $GF(2^n)$ -mode. The radix-(2, 4) multiplier is in fact the first member of the dual-radix multiplier family, which also includes radix-(4, 8) and radix-(8, 16) [46]. We only include the radix-(2, 4) multiplier to keep the discussion simple.

4.2.1. Precomputation in Montgomery Multiplication Algorithm

The dual-radix unified multiplier architecture utilizes a precomputation technique in order to decrease the critical path delay of the original unified multiplier in [47]. Note that Step 4 of the Algorithm A computes

$$c := (c + a_i \cdot b + q \cdot p) / 2^k,$$

where division by 2^k is simply a right shift by k bits and q is calculated in the previous step. Depending on the

radix value chosen for the multiplier, the k -bit digit q can be determined by the least significant digits (LSD) of b , p and c , and the current digit of a . Similarly, the multiple of b that participates in the addition is determined solely by a_i . As a result, the LSDs of the operands, a_i , b_0 , and c_0 will determine which one of the values in $\{0, b, p, b + p, 2p, 2b, 2b + 2p, \dots\}$ is added to the partial result c . If one precomputes and stores the value of $b + p$, the calculations in Step 4 can be significantly simplified.

There are two implications of the precomputation technique. Firstly, the precomputed value must be stored, implying an increase in the register space. And secondly, there must be a so-called selection logic to select which multiples of b and p must participate in the addition in Step 4. The selection logic can be designed in such a way that it is parallel to PU and thus it results in no overhead in the critical path delay. On the other hand, the precomputation technique also simplifies the design since Step 4 can be performed with only one addition, once the selection logic generates its output.

4.2.2. Processing Unit for Dual-Radix Multiplier

As pointed out earlier, a processing unit (PU) is basically responsible for performing Step 3 and Step 4 of Algorithm A. Since the multiplier uses radix-2 for $GF(p)$, the least-significant bits (LSB) of the operand digits, a_i , b_0 , and c_0 determine which one of the values in $\{0, b, p, b + p\}$ will be added to the partial result c . Multiplication is performed in radix-4 in $GF(2^n)$. Therefore, the LSDs (least significant digits) of b , p , and c and of the current digit of a are required to determine q . The LSB of p is always 1, then only $p_{0,1}$, the second least significant bit of the modulus,

is included in the computations. Consequently, $a_{i,1}$, $a_{i,0}$, $b_{0,1}$, $b_{0,0}$, $c_{0,1}$, $c_{0,0}$ and $p_{0,1}$ determine one of the following values to be added to the partial result: $\{0, b, p, b + p, x \cdot b, x \cdot p, x \cdot (b + p)\}$ (Note that $a_{i,j}$ is the j th least significant bit of i th digit of a). Multiplication by x results in shifting one bit to the left, hence it is identical to multiplication by 2. Division by x^k and 2^k are identical operations and the latter is used to denote the right shift operation by k bits.

In Figure 7, the architecture of the processing unit (PU) used in the dual-radix multiplier is illustrated. The local control circuit in Figure 7 contains the selection logic which generates the signals, to determine which multiples of b and p will be in the calculations. For example, the selection signal $((10), (11))$ indicates that Step 4 will be $c := (c + 3b + 2p)/2^k$.

4.3. Support for Ternary Extension Fields, $GF(3^n)$

The Montgomery multiplication algorithm for $GF(3^n)$, which is very similar to Algorithm B, is given below [39]:

Algorithm C

Input: $a(x)$, $b(x)$, $p(x)$, and m

Output: $c(x)$

Step 1: $c(x) := 0$

Step 2: for $i = 0$ to $m - 1$

Step 3: $q(x) := (c_0(x) + a_i(x) \cdot b_0(x)) \cdot p'_0(x) \pmod{x^k}$

Step 4: $c(x) := (c(x) + a_i(x) \cdot c(x) + q(x) \cdot p(x))/x^k$

Only difference is due to the computation of $p'_0(x)$, which is $p'_0(x) = 2 \cdot p_0^{-1}(x) \pmod{x^k}$ (instead of $p'_0(x) = p_0^{-1}(x) \pmod{x^k}$ in Algorithm B).

Original unified multiplier architecture [47] utilizes two

layers of (3×2) dual-field adder arrays to perform addition operations in Steps 3 and 4 of Montgomery multiplication algorithm. This is due to the fact that multiplicand (b or $b(x)$) and modulus (p or $p(x)$) are assumed to be always in non-redundant form. If the result of a multiplication, which is produced in redundant form (e.g. carry-save representation), is needed for subsequent multiplications, it is immediately converted to non-redundant representation. In order to eliminate the need for conversion from redundant to non-redundant representation and associated circuitry, all operands can be kept in redundant form throughout the entire elliptic

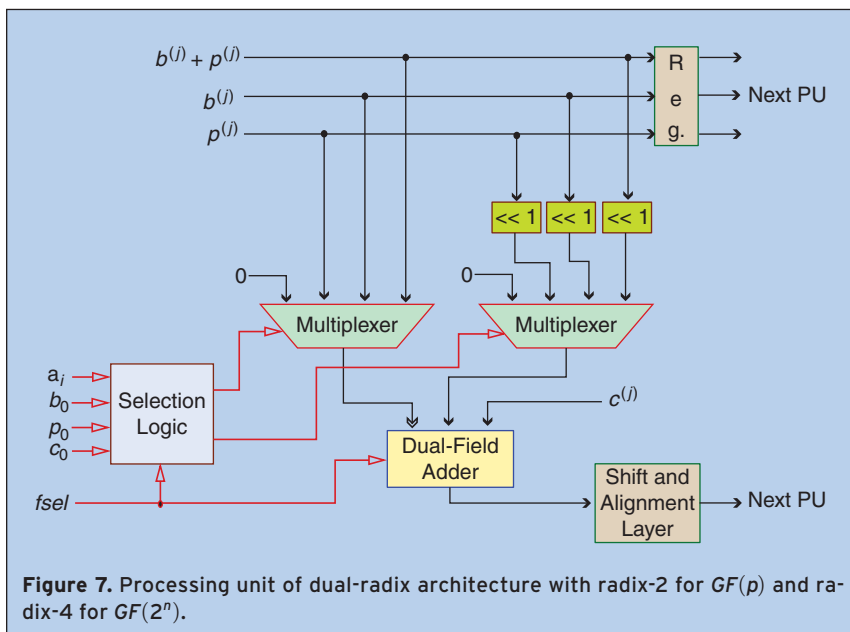

Figure 7. Processing unit of dual-radix architecture with radix-2 for $GF(p)$ and radix-4 for $GF(2^n)$.

Implementations of unified multiplier in ASIC standard cell library demonstrate that unified multiplier significantly improves area x time metric.

curve computations (e.g. elliptic curve scalar point multiplication). This, however, requires using (4×2) adder arrays to perform addition (or subtraction) of two redundant form integers. Although it is laden with area and CPD overhead, one slice of (4×2) adder can easily be modified to perform one-digit addition in three fields $GF(p)$, $GF(2^n)$, and $GF(3^n)$ as explained in [39]. A multiplier that can operate in three fields can be designed in the same way the original unified multiplier [47] is designed. Two important differences of the new unified multiplier from the original unified multiplier is that it has two control bits (as opposed to one in the original multiplier) to select the field mode ($GF(p)$, $GF(2^n)$, or $GF(3^n)$), and that the processing unit (PU) has now two layers of (4×2) modified-adder arrays. In addition, RSD arithmetic is employed instead of carry-save arithmetic.

In order to assess the merits of unified multiplier that performs multiplications of three fields in the same datapath, one needs to compare the unified multiplier against a hypothetical architecture which has three separate multipliers for these three fields. The {area \times CPD} metric can be used in order to figure out the balance between saving in the area and overhead in the critical path delay that the unified multiplier will have when compared to the hypothetical design. Implementations of both new unified multiplier and hypothetical design in ASIC standard cell library demonstrate that the new unified multiplier considerably improves {area \times time} metric when compared to the hypothetical design in [39] and the classical unified design in [47].

5. Inversion

In this section, we give multiplicative inversion algorithms, which allow very fast and area-efficient unified hardware implementations. The presented algorithms are based on the Montgomery inversion algorithms given in [23]. While there are several unified inversion units reported in the literature [16, 43, 45] that compute in two fields $GF(p)$ and $GF(2^n)$ there has been no unified inversion unit proposed to operate in three fields. Therefore, we limit our discussion, which is based on the techniques and algorithms in [45], only to $GF(p)$ and $GF(2^n)$.

5.1. The Montgomery Inversion Algorithms for $GF(p)$ and $GF(2^n)$

The Montgomery inversion algorithm as defined in [23] computes

$$b = a^{-1}2^n \pmod{p}, \quad (1)$$

given $a < p$, where p is a prime number and $n = \lceil \log_2 p \rceil$. The algorithm consists of two phases: Phase I (Algorithm D) whose output is the integer r such that $r = a^{-1}2^k \pmod{p}$, where $n \leq k \leq 2n$ and Phase II is a correction step and can be modified as shown in [44] in order to calculate a slightly different inverse that can more precisely be called *Montgomery inverse*:

$$b = \text{MonInv}(a2^n) = a^{-1}2^n \pmod{p}, \quad (2)$$

Algorithm D

Phase I

Input: $a2^n \in [1, p-1]$ and p
 Output: $r \in [1, p-1]$ and k ,
 where $r = a^{-1}2^{k-n} \pmod{p}$ and $n \leq k \leq 2n$

Step 1: $u := p, v := a2^n, r := 0$, and $s := 1$
 Step 2: $k := 0$
 Step 3: while $(v > 0)$
 Step 4: if u is even then $u := u/2, s := 2s$
 Step 5: else if v is even then $v := v/2, r := 2r$
 Step 6: else if $u > v$ then
 $u := (u-v)/2, r := r+s, s := 2s$
 Step 7: else $v := (v-u)/2, s := s+r, r := 2r$
 Step 8: $k := k+1$
 Step 9: if $r \geq p$ then $r := r-p$
 Step 10: return $r := p-r$ and k

The second phase of the Montgomery inversion algorithm simply performs $2n-k$ left (modular) shifts as a correction step to obtain $a^{-1}2^n \pmod{p}$ from $a^{-1}2^{k-n} \pmod{p}$. The left shift operations are modular in the sense that a modular reduction operation is performed whenever the shifted value exceeds the modulus.

In cases where word multiplications can be efficiently computed, another method based on Montgomery multiplication is proposed for Phase II computation in [44]. Considering $R^2 \equiv 2^{2n} \pmod{p}$ is already a precomputed value in Montgomery arithmetic, two Montgomery multiplications are required to implement Phase II of the Montgomery inverse:

$$\begin{aligned} \text{MonMult}(r, R^2) &\equiv (a \cdot 2^n)^{-1} \cdot 2^k \cdot 2^{2n} \cdot 2^{-n} \\ &\pmod{p} \equiv a^{-1} \cdot 2^k \pmod{p} \end{aligned}$$

$$\begin{aligned} \text{MonMult}(a^{-1} \cdot 2^k, 2^{2n-k}) &\equiv a^{-1} \cdot 2^k \cdot 2^{2n-k} \cdot 2^{-n} \\ &\pmod{p} \equiv a^{-1} \cdot 2^n \pmod{p}. \end{aligned}$$

An efficient way to accelerate inversion operation is to apply a technique known as multibit shifting.

The cost of the Phase II in the latter method is two Montgomery multiplication operation while the former method requires $2n - k$ multi-word shifts and expectedly $(2n - k)/2$ multi-word additions. The experiments in [44] show that the latter method gives a considerable speedup in software implementations whereby word size multiplier units facilitate fast Montgomery multiplication operation. However, the former method is more suitable for hardware implementations since shift operations are usually inexpensive in hardware. With increasing number of hardwired multipliers in FPGA target devices, the latter method [44] may offer advantages for FPGA implementations.

We aptly call this new inversion Montgomery inversion since it takes a field element in the form of $a2^n \pmod{p}$ and returns $a^{-1}2^n \pmod{p}$. This is known as the *residue form* of a field element. In cryptographic calculations (RSA, elliptic curve or pairing-based) all inputs are first transformed to the residue form, intermediate and final results are all obtained in residue form. The final results are transformed back to normal form after the cryptographic calculations are finished.

Montgomery multiplication and Montgomery inversion as defined here together form what we call *Montgomery arithmetic* for finite fields, whereby all values are in residue form. Note that Montgomery addition/subtraction operations are identical normal modular addition/subtraction operations. Having a full set of Montgomery arithmetic is especially useful in elliptic curve and pairing-based cryptography.

The Montgomery inversion algorithm for $GF(2^n)$ is obtained as follows. We first replace all additions and subtractions in Algorithm D with addition in $GF(2^n)$. Since it is possible to perform addition (and subtraction) with carry and addition without carry in a single arithmetic unit, this difference does not cause a change in the control unit of a unified inversion unit. However, Step 3 and Step 6 of Algorithm D need to be modified as follows:

Step 3: while $(u(x) \neq 0)$
 ...
 Step 6: else if $\deg(u(x)) \geq \deg(v(x))$ then
 $u(x) := (u(x) + v(x))/x,$
 $r(x) := r(x) + s(x), s(x) := xs(x).$

In addition, Step 8 through 9 must also be modified:

Step 9: if $s_{n+1} = 1$ then $s(x) := s(x) + xp(x)$

Step 10: if $s_n = 1$ then $s(x) := s(x) + p(x)$
 Step 11: return $s(x)$ and $k.$

While these changes are small, they may necessitate a significant change to the control circuitry. The most important challenge is to design a unified version of Step 6 since other steps can easily be performed in unified fashion. In literature, several solutions are proposed to circumvent this problem. In [45], the unified architecture implements Step 6 as comparison of bit lengths of variables u and v . The method adopted in [16] is to implement Step 6 as an integer comparison, where the integer values of $u(x)$ and $v(x)$ are used. Since binary polynomials are just bit strings, all needs to be done is to treat these binary strings as integers.

An efficient way to accelerate inversion operation is to apply a technique known as *multibit shifting* as described in both [16] and [45]. Algorithm D terminates when $v = 0$ and $u = 1$. Right shifting operations by one bit applied to u and v in Steps 4 through 7, play a dominant role to diminish them to their final values. If we can shift them more than one bit to the right in every iteration of the while loop, we accelerate the execution of the algorithm. Indeed, u and v may happen to have more than one 0 bit in the least significant positions of their binary representations (e.g. 00, and 000). To detect two or three consecutive 0 bits in the least significant bit positions is not expensive in hardware. However, increasing the number of least significant bits to check has two important drawbacks. Firstly, detection circuit will be very complicated. And secondly, the probability that a variable having more than three 0 bits in its least significant positions will quickly diminish. The experiments in [16] and [45] show that 3-bit shifting provides considerable advantage, which disappear for larger shift amounts.

6. Other Techniques for Accelerating Finite Field Operations

In this section, we briefly outline several other techniques to accelerate finite field operations proposed in the literature.

6.1. Incomplete Modular Arithmetic for $GF(p)$

The finite field arithmetic for $GF(p)$ produces completely reduced integers. In other words, the result of an arithmetic operation is integer $r < p$. However, in platforms where word-based arithmetic is adopted (e.g.

Pairing-based cryptography necessitates efficient algorithms for general extension field arithmetic.

microprocessor-based systems), allowing a number to grow to the word boundary can be advantageous. Assuming that $n = \lceil \log_2 p \rceil$ and $m = ew \geq n$ where w is the word size and that e is the number of words needed to represent p , for an element $r \in GF(p)$ we may have $r > p$ and $r \leq 2^m - 1$. Note that $2^m - 1 \geq p$. The number is reduced whenever we have $r > 2^m - 1$, which can be detected by checking whether the $s + 1$ st word of r is 1. This check is much easier than checking $r > p$ since the latter requires bit manipulation in a word-based computer.

Incomplete modular arithmetic avoids bit-level operations which are slow on microprocessors and performs word-level operations which are significantly faster. Yanik et al. [57] propose algorithms for incomplete modular arithmetic, namely modular addition, subtraction and multiplication using Montgomery arithmetic for $GF(p)$. They report a speedup of around 10% in elliptic curve cryptography through incomplete modular arithmetic. Algorithms for incomplete modular inversion can be found in [44].

6.2. Scaled Modulus for efficient $GF(p)$ arithmetic

The modulus scaling was introduced by Walter [54]. The method is based on multiplying the prime modulus p by a small integer s to obtain a new modulus, $m = p \cdot s$. Here, p is a prime of random form for which the modular reduction can be difficult while the new modulus m has special form (e.g. $2^k - c$) that facilitates reducing the modular reduction into simple addition/subtraction operations.

Working with new modulus m will produce a result a that is congruent to the residue obtained by reducing a modulo p . This follows from the fact that reduction is a repetitive subtraction of the modulus. Subtracting m is equivalent to subtracting p , s times and thus $(a \bmod m) \bmod p \equiv a \bmod p$. When a scaled modulus is used, residues will be in the range $[0, m - 1] = [0, sp - 1]$. The number is partially reduced and essentially represented using $\lceil \log_2 s \rceil$ more bits than necessary. Consequently, it will be necessary that the final result is reduced by p to obtain a fully reduced representation. Naturally, this final reduction can be postponed to the end of cryptographic operation.

Öztürk et al. [40] proposed a new method for finding appropriate scaled moduli and reported a low-power implementation of elliptic curve cryptography based on the technique. The implementation uses the scaled moduli $2^{167} + 1 = 3 \cdot 0x2AAAAAAAAAAAAAAAAAAAAAAAAAAAAA$

AAAAAAAAAAAAAAB, where the prime is a 166-bit integer. Taking advantage of a simple modular reduction due to low-weight special modulus $2^{167} + 1$, the implementation in [40] is one of the most compact realizations of elliptic curve cryptography in literature.

6.3. Arithmetic for General Extension Fields

With the increasing importance of pairing-based cryptography, developing efficient algorithms for general extension field arithmetic becomes a popular research area. Pairing operations uses arithmetic in extension $GF(q^k)$ of the finite field $GF(q)$ where the elliptic curve group is originally defined over the base field $GF(q)$. The elements of an extension field are represented as polynomials of degree of at most $k - 1$, where the coefficients of the polynomial are in the base field $GF(q)$. The arithmetic of extension field $GF(q^k)$ is usually performed as regular polynomial arithmetic. The most important operation of $GF(q^k)$ is again multiplication, which comprises polynomial multiplication and reduction by the irreducible polynomial of degree k used to define the extension field. Using irreducible polynomials of low-weight is a preferred method to decrease the complexity of the reduction phase of the multiplication in $GF(q^k)$. For prime extension fields, the polynomial $x^k - \beta$ is an irreducible polynomial for specifically chosen values of β [12]. $x^k - \beta$, where β is a small number, will transform the polynomial reduction into simple polynomial addition operations.

The polynomial multiplication, which is the first part of $GF(q^k)$ multiplication is generally harder to implement. For efficient computation of pairing operation, k is usually chosen as a relatively small integer in the range of [2, 12]. Some of the typical extension fields used in pairing operations are $GF(p^2)$, $GF(p^{12})$, $GF((2^m)^2)$, and $GF((3^m)^6)$. For small extension degrees such as $GF(p^2)$ and $GF((2^m)^2)$, Karatsuba-based methods [12] usually provides the best performance. For larger extension degrees, tower field constructions result in better implementations.

In tower field constructions, there may be several alternatives for the representation of the field elements. For instance, the ternary extension field $GF((3^m)^6)$ can be constructed as $GF(((3^m)^2)^3)$. This means that we need an irreducible polynomial of degree two over $GF(3^m)$ first to construct $GF(3^{2m})$. Then an irreducible polynomial of degree three over $GF(3^{2m})$ is needed to construct $GF((3^{2m})^3)$. The choice of irreducible polynomials

Montgomery multiplication architectures for prime finite field multiplication can be used for RSA operations without any modification.

will greatly influence the efficiency of the implementation. Similarly, the fact that multiplication in the tower field consists of many independent $GF(3^m)$ arithmetic operations facilitates different arrangements to take advantage of the parallelism due to the independent operations. This is especially useful in hardware implementations where a functional unit for an arithmetic operation can be replicated as many times as needed to render faster implementations [32]. There is a need for further research in the area of tower field arithmetic to accelerate pairing-based cryptography.

7. Finite Field Arithmetic as a Building Block of Cryptographic Algorithms

7.1. RSA

Rivest, Shamir and Adleman proposed a novel cryptographic algorithm in 1978 [41] that can be used for key exchange and electronic signature as well as encryption. Its security relies on the *Integer Factorization Problem* which is, generally believed to be a hard problem if the related numbers are sufficiently large.

7.1.1. RSA Setup

Let us assume that Bob wants to send a secret message to Alice who should have a public-private key pair. Her public key is a pair of two large integers (n, e) and her private key is d , which is another large integer. The integer n , called the modulus, is the multiplication of two large prime numbers, p and q . It is computationally infeasible to factor n into p and q when they are sufficiently large. Euler's Totient function, $\Phi(n) = (p-1)(q-1)$, is used to determine the public exponent e and private exponent d . The public exponent e can be chosen randomly provided that $GCD(e, \Phi(n)) = 1$; however it is usually chosen as a small number for fast encryption. The private exponent d is the multiplicative inverse of e with respect to modulus $\Phi(n)$.

7.1.2. RSA Encryption/Decryption

To send a message m securely to Alice, Bob performs the modular exponentiation operation $c \equiv m^e \pmod{n}$. Upon receiving the ciphertext message c , Alice performs the modular exponentiation $c^d \pmod{n} = m$. Since Alice is the only one who knows her private key d , only she can perform this computation and obtains the plaintext message m . As one can easily observe, both RSA encryption and decryption operations are

nothing but modular exponentiations over very large numbers. A modular exponentiation is comprised of many modular multiplications, which are usually difficult to perform efficiently since the operands are large integers.

7.1.3. RSA Implementation

Since RSA modulus n is a composite number, RSA arithmetic is performed in the ring \mathcal{Z}_n . In our context, the basic difference between a ring of this type and prime finite field is that inversion in \mathcal{Z}_n is not defined for every element of \mathcal{Z}_n . However, RSA does not require inversion but only multiplication in \mathcal{Z}_n . Moreover, RSA modulus is an odd integer. Therefore, the Montgomery multiplication architectures for prime finite field multiplication can be used for RSA operations without any modification.

For RSA encryption and decryption, we perform modular exponentiation, which are nothing but repeated modular multiplications with an odd modulus. Algorithm A is a generic description of the Montgomery modular multiplication where radix can be anything from 2 to the wordsize of a computer. A pipelined organization of the multiplier as shown in Figure 6 is usually the best way for the hardware implementation of Algorithm A both in terms of area and time complexities. These types of architectures are both parametric and scalable. Optimum number of pipeline stages can be determined for a given precision and available resources.

Similarly, the radix selection is also determined by the available resources. In ASIC realizations, small radix values (e.g. 2, 4, 8) are preferred [53, 52] since higher radix values necessitates the design of fast high-radix multipliers, which may not yield the desired efficiency. On the other hand, in software and FPGA realizations [28, 49, 38] higher radices are preferred since those platforms feature highly-efficient and fast (hardwired in FPGA) word-based multipliers. For example, Spartan 3E FPGA devices [56] contain very-fast hardwired 18×18 bit multipliers. The design in [38] makes use of these multipliers and pipeline organization to obtain the most compact and fast Montgomery multipliers. The required speed, available resources and utilization determine the number of pipeline stages for a given precision. Utilization is an important metric that needs to be inspected to see whether the used resources are put into good use. If utilization is low, this may mean that it is possible to obtain similar efficiency using less resources. However,

In software implementations, inversion is usually very slow compared to multiplication.

this is, most of the time, not immediate and the optimum designs require careful time and dependency analyses of the used algorithm.

Building a modular exponentiation circuit over an efficient modular multiplier is usually straightforward. Depending on the modular exponentiation algorithm used, there exists some parallelism to accelerate the computation [38, 50]. Attacks on specific implementations of the modular exponentiation such as [30, 31] and fault-attacks [2] can compromise or weaken RSA algorithm. Several exponentiation algorithms [22, 20, 21] and some randomization techniques [15] can help protect the RSA implementation against these attacks. In most applications, certain degree of protection against these attacks is necessary.

7.2. Elliptic Curve Cryptography

Elliptic curve cryptography was proposed by Neal Koblitz [27] and Victor Miller [34], independently. The solutions to the equation $y^2 \equiv x^3 + ax + b$ in $GF(p)$ along with an abstract point at infinity \mathcal{O} forms an additive group G , which is suitable for cryptographic usage². Discrete logarithm defined over the elliptic curve group is believed to be harder than discrete logarithm in the multiplicative group \mathcal{Z}_p^* .

The solutions are also known as points, represented by two coordinates $P = (x, y) \in GF(p)$, which are referred as *affine coordinates*. The group addition (i.e. point addition or doubling) requires a couple of multiplications, several additions and one inversion operation in $GF(p)$. If affine coordinates are used, multiplicative inversion is generally the most time consuming operation. Projective coordinates that represent elliptic curve points using three coordinates in $GF(p)$ eliminate most of the inversions operation at the expense of more multiplication operations. Nevertheless, projective coordinates require much more temporary storage space during the computations. For point arithmetic with projective coordinates, refer to [11].

Elliptic curve cryptography is the main motivation for unified arithmetic since it is possible and sometimes more efficient to use elliptic curves over different finite fields. Therefore, it is definitely useful to have an architecture that can efficiently perform arithmetic in diverse set of finite fields in the same datapath. This will decrease the cost of the design and increase the compactness.

7.2.1. Coordinate Selection: Projective or Affine?

An important design issue is whether to use projective or affine coordinates. If the inversion is roughly more than 10 times slower than multiplication, then using projective coordinates results in a faster computation of elliptic curve arithmetic. In software implementations, inversion is usually very slow compared to multiplication; therefore it is almost always better to use projective coordinates. Moreover, a large main memory eliminates the concerns about higher storage requirements of projective coordinates.

However, hardware implementations offer a different perspective. The inversion operation can be computed considerably faster through a specifically designed hardware module than in software. If we have a fast inversion module, affine coordinates can provide better or comparable timings. The question here is whether the hardware cost of an inversion unit outweighs its advantage. On the other hand, using projective coordinates has also an area overhead due to its higher demands on temporary registers. In ASIC, registers are expensive to realize compared to combinational circuits. Consequently, area used to implement inversion unit can become comparable to the area used for additional temporary registers used in projective coordinates. This fact was first pointed out in [43]. Recently, an extensive study in elliptic curve realizations in ASIC [25] finds out that an affine coordinate implementation performs much better than a projective coordinate implementation in terms of both timing and area.

FPGA implementations of elliptic curve cryptography may have a similar perspective to software implementation whereby using projective coordinates is likely to be a better choice. Two factors affect this conclusion: i) registers are not very expensive compared to combinational logic where both are implemented similar ways and ii) fast, hardwired digit multipliers FPGAs facilitate much faster field multiplication compared to the inversion operation in prime fields. However, for a decisive conclusion, further research is necessary.

7.2.2. Recycling of Hardware Modules

Unlike RSA that mainly requires modular multiplication, elliptic curve cryptography needs different field operations, namely addition/subtraction, multiplication/squaring, and inversion/division. A compact (area-efficient) architecture, is only possible through maximizing

²Elliptic curves over binary extension or general extension fields are defined similarly. See [33] for more details.

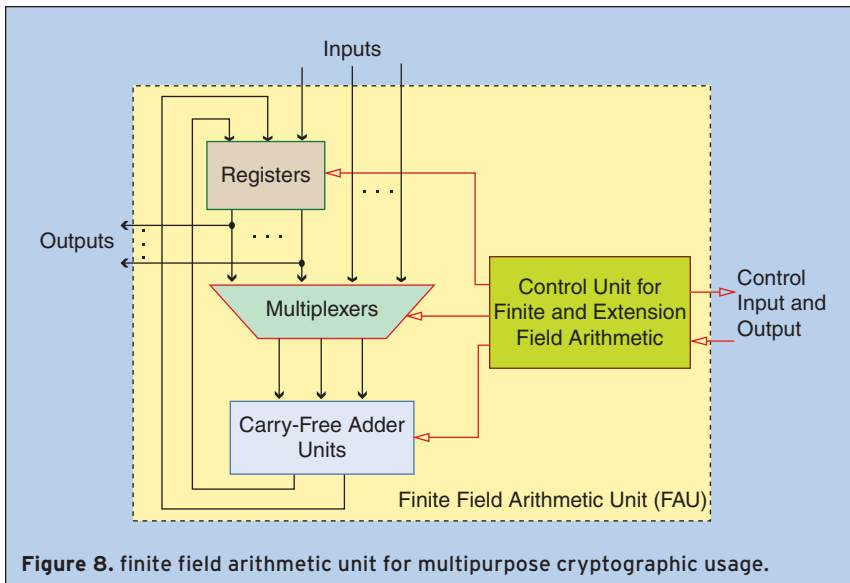

Figure 8. finite field arithmetic unit for multipurpose cryptographic usage.

tions are very fast since carries do not propagate. A finite field arithmetic unit based on carry-free adders that can be utilized in different cryptographic applications is illustrated in Figure 8.

7.3. Pairing-Based Cryptography

Bilinear pairing operation defined over elliptic curves emerges as an important cryptographic primitive after a plethora of recent cryptographic protocols employs them, such as non-interactive key agreement scheme by [42], three party Diffie-Hellman key exchange scheme by [19], identity based encryption scheme proposed by

hardware-sharing among these various operations. Successful designs such as [39, 25] focus on recycling the same set of registers and functional units for different field operations. Both designs in [39, 25] utilize carry-free adders (RSD or carry-save adders) as the fundamental arithmetic unit in all field operations. Carry-free adders that can be used to implement all field opera-

Boneh and Franklin [5], short group signatures [4], identity based ring signature schemes [10] and finally direct anonymous attestation schemes [6, 7, 9, 8].

Let G_1, G_2 and G_M be cyclic groups of some large prime order q . Then, $\hat{e}: G_1 \times G_2 \rightarrow G_M$ is a **bilinear map**, which is efficiently computable and has the following property: $\forall P \in G_1$, and $\forall Q \in G_2$, and $\forall a, b \in \mathbb{Z}_q$, $\hat{e}(aP, bQ) = \hat{e}(P, Q)^{ab}$ (Bilinearity).

Efficient constructions use additive groups of elliptic curves for G_1 and G_2 , and multiplicative group G_M in an extension of a finite field $GF(q^k)$. $GF(q)$ here is the finite field over which G_1 is defined and k is known as the *embedding degree* of G_1 . Embedding degree serves as a security parameter.

For efficiency reasons the finite fields $GF(p)$, $GF(2^n)$, and $GF(3^m)$ are three popular fields used to construct additive elliptic curve groups, G_1 and G_2 . Therefore, for fast pairing computations, arithmetic in these three fields and in their extensions (i.e. prime extension $GF(p^k)$, and tower fields $GF((2^n)^k)$ and $GF((3^m)^k)$) needs to be performed efficiently. The embedding degree k cannot be too large for the pairing operation to be efficiently computable. The practical range of k is usually [2, 12].

Pairing operation requires both finite field (extension and base)

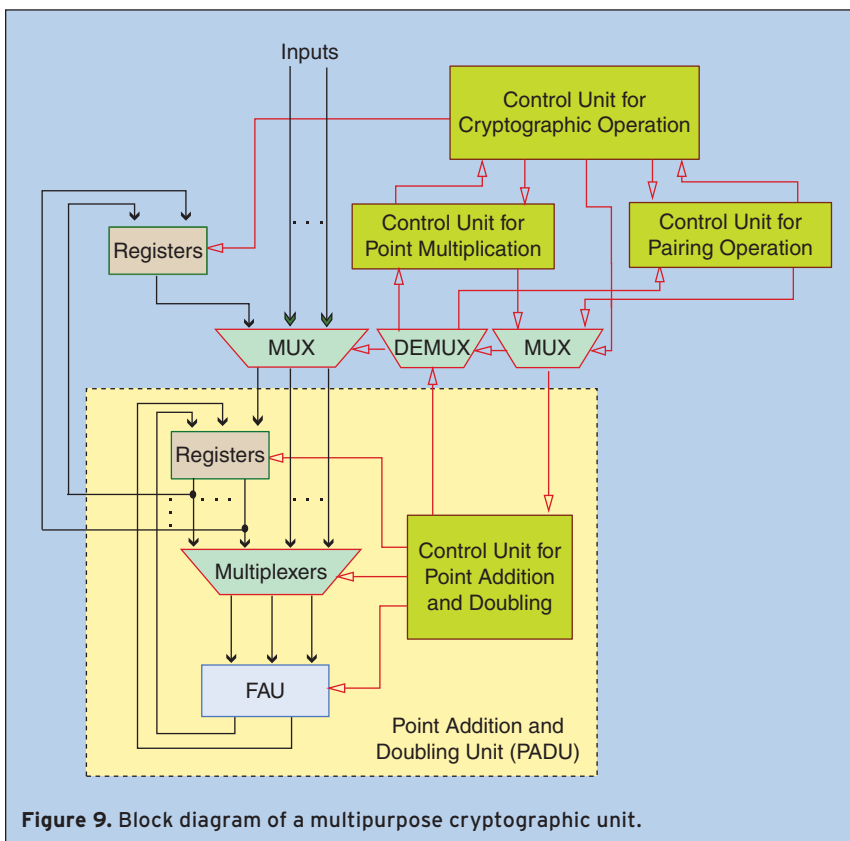

Figure 9. Block diagram of a multipurpose cryptographic unit.

and elliptic curve point arithmetic (point addition and doubling). A block diagram of a multi-purpose cryptographic unit that can perform diverse set of arithmetic operations is shown in Figure 9. The hierarchical design of control units allows using the same units in different cryptographic operations. This design approach also facilitates replication of finite field arithmetic units to exploit the concurrency in the computations.

Importance of pairing operation is that it forms a motivation for designing efficient arithmetic architectures for extension and tower fields, elliptic curves defined over larger finite fields (e.g. prime field with a 512-bit prime), and elliptic curves over ternary fields. Since efficiency and security requirements of pairing-based cryptography still pose design challenges, there is a room for further research on the design and implementation of novel architectures for the arithmetic operations involved in pairing computations.

8. Conclusions

This paper covers algorithms and architectures for multiplicative groups, rings, finite fields for implementing the RSA and Diffie-Hellman, elliptic curve and pairing-based cryptography. The algorithms we present can be generically applied; particularly, we focused on polynomial bases for binary, ternary and general extension fields. We gave a comprehensive summary of finite field arithmetic in cryptography, covering all basic algorithms, architectures, and building blocks in order to create time-, power-, and space-efficient implementations of finite field operations. The basic arithmetic operations, i.e., addition, multiplication, and inversion in finite fields $GF(q)$ where $q = p^k$, particularly, p is 2 or 3 or an arbitrary large prime. While these choices seem to imply a diverse set of design possibilities, it is also possible to create unified and versatile implementations where a single hardware architecture supports several different fields with a little extra cost.



Erkay Savaş received the BS (1990) and MS (1994) degrees in electrical engineering from the Electronics and Communications Engineering Department at Istanbul Technical University. He completed the Ph.D. degree in the Department of Electrical and Computer Engineering at Oregon State University in June 2000. He had worked for various companies and research institutions before he joined Sabanci University as an assistant professor in 2002. He is the director of the Cryptography and Information Security Group (CISec) of Sabanci University. His research interests include

cryptography, data and communication security, privacy in biometrics, trusted computing, security and privacy in data mining applications, embedded systems security, and distributed systems. He is a member of IEEE, ACM, the IEEE Computer Society, and the International Association of Cryptologic Research (IACR).



Çetin Kaya Koç received his Ph.D. in Electrical & Computer Engineering from University of California Santa Barbara in 1988. He was an Assistant Professor at University of Houston (1988–1992), Assistant, Associate and Full Professor at Oregon State University (1992–2007). He established Information Security Laboratory at Oregon State University, and received Award for Outstanding and Sustained Research Leadership in September 2001.

His research interests are in cryptographic hardware and embedded systems, secure hardware design, side-channel attacks and countermeasures, algorithms and architectures for computer arithmetic and finite fields.

Koç has also been in the editorial boards of *IEEE Transactions on Computers* (2003–2008) and *IEEE Transactions on Mobile Computing* (2003–2007). Furthermore, he was a guest co-editor of two issues (April 2003 & November 2008) of *IEEE Transactions on Computers* on cryptographic and cryptanalytic hardware and embedded systems.

Koç was elected as IEEE Fellow in 2007 for his contributions to cryptographic engineering.

Currently, Koç is a professor of Computer Science at Istanbul Şehir University and an adjunct professor in the Department of Computer Science and the College of Creative Studies at University of California Santa Barbara.

References

- [1] A. Avizienis, "Signed-digit number representations for fast parallel arithmetic," *IRE Trans. Electron. Comput.*, vol. EC, no. 10, pp. 389–400, Sept. 1961.
- [2] D. Boneh, R. A. Demillo, and R. J. Lipton, "On the importance of eliminating errors in cryptographic computations," *J. Cryptology*, vol. 14, pp. 101–119, 2001.
- [3] D. Boneh and M. K. Franklin, "Identity-based encryption from the Weil pairing," in *CRYPTO (LNCS, vol. 2139)*, J. Kilian, Ed. New York: Springer-Verlag, 2001, pp. 213–229.
- [4] D. Boneh, X. Boyen, and H. Shacham, "Short group signatures," in *CRYPTO (LNCS, vol. 3152)*, M. K. Franklin, Ed. New York: Springer-Verlag, 2004, pp. 41–55.
- [5] D. Boneh and M. K. Franklin, "Identity-based encryption from the Weil pairing," in *CRYPTO (LNCS, vol. 2139)*, J. Kilian, Ed. New York: Springer-Verlag, 2001, pp. 213–229.
- [6] E. F. Brickell, J. Camenisch, and L. Chen, "Direct anonymous attestation," in *Proc. ACM Conf. Computer and Communications Security*, V. Atluri, B. Pfitzmann, and P. D. McDaniel, Eds. ACM, 2004, pp. 132–145.
- [7] E. Brickell, L. Chen, and J. Li, "A new direct anonymous attestation scheme from bilinear maps," in *TRUST (LNCS, vol. 4968)*, P. Lipp, A.-R. Sadeghi, and K.-M. Koch, Eds. New York: Springer-Verlag, 2008, pp. 166–178.
- [8] L. Chen, P. Morrissey, and N. Smart. (2009). *DAA: Fixing the pairing based protocols*. *Cryptology ePrint Archive*, Rep. 2009/198 [Online]. Available: <http://eprint.iacr.org/>

- [9] L. Chen, P. Morrissey, and N. P. Smart, "Pairings in trusted computing," in *Pairing (LNCS, vol. 5209)*, S. D. Galbraith and K. G. Paterson, Eds. New York: Springer-Verlag, 2008, pp. 1–17.
- [10] S. S. M. Chow, L. C. K. Hui, and S.-M. Yiu, "Identity based threshold ring signature," in *ICISC (LNCS, vol. 3506)*, C. Park and S. Chee, Eds. New York: Springer-Verlag, 2004, pp. 218–232.
- [11] H. Cohen, A. Miyaji, and T. Ono, "Efficient elliptic curve exponentiation using mixed coordinates," in *ASIACRYPT (LNCS, vol. 1514)*, K. Ohta and D. Pei, Eds. New York: Springer-Verlag, 1998, pp. 51–65.
- [12] A. J. Devegili, C. Higeartaigh, and M. Scott. (2006). *Multiplication and squaring on pairing-friendly fields. Cryptology ePrint Archive*, Rep. 2006/471 [Online]. Available: <http://eprint.iacr.org/>
- [13] W. Diffie and M. E. Hellman, "New directions in cryptography," *IEEE Trans. Inform. Theory*, vol. 22, pp. 644–654, Nov. 1976.
- [14] S. E. Eldridge, "An faster modular multiplication algorithm," *Int. J. Comput. Math.*, vol. 40, no. 1, pp. 63–68, 1991.
- [15] C. Giraud, "An RSA implementation resistant to fault attacks and to simple power analysis," *IEEE Trans. Comput.*, vol. 55, no. 9, pp. 1116–1120, 2006.
- [16] A. A.-A. Gutub, A. F. Tenca, E. Savaş, and Ç. K. Koç, "Scalable and unified hardware to compute Montgomery inverse in GF (p) and GF (2^k)," in *CHES (LNCS, vol. 2523)*, B. S. Kaliski, Jr., Ç. K. Koç, and C. Paar, Eds. New York: Springer-Verlag, 2002, pp. 484–499.
- [17] G. Hachez and J.-J. Quisquater, "Montgomery exponentiation with no final subtractions: Improved results," in *CHES (LNCS, vol. 1965)*, Ç. K. Koç and C. Paar, Eds. New York: Springer-Verlag, 2000, pp. 293–301.
- [18] *Standard Specifications for Public-Key Cryptography*, IEEE P1363, 2000.
- [19] A. Joux, "A one round protocol for tripartite Diffie-Hellman," in *ANTS (LNCS, vol. 1838)*, W. Bosma, Ed. New York: Springer-Verlag, 2000, pp. 385–394.
- [20] M. Joye, "Highly regular right-to-left algorithms for scalar multiplication," in *CHES (LNCS, vol. 4727)*. New York: Springer-Verlag, 2007, pp. 135–147. [21] M. Joye, "Highly regular m-ary powering ladders," in *Selected Areas in Cryptography (LNCS, vol. 5867)*, M. J. J. Jr., V. Rijmen, and R. Safavi-Naini, Eds. New York: Springer-Verlag, 2009, pp. 350–363.
- [22] M. Joye and S.-M. Yen, "The Montgomery powering ladder," in *CHES (LNCS, vol. 2523)*, B. S. Kaliski, Jr., Ç. K. Koç, and C. Paar, Eds. New York: Springer-Verlag, 2002, pp. 291–302.
- [23] B. S. Kaliski, Jr., "The Montgomery inverse and its applications," *IEEE Trans. Comput.*, vol. 44, no. 8, pp. 1064–1065, Aug. 1995.
- [24] B. S. Kaliski, Jr., Ç. K. Koç, and C. Paar, Eds., "Cryptographic hardware and embedded systems—CHES 2002," in *Proc. 4th Int. Workshop (LNCS, vol. 2523)*, Redwood Shores, CA, Aug. 13–15, 2002. New York: Springer-Verlag, 2003.
- [25] D. Karakoyunlu, F. K. Gurkaynak, B. Sunar, and Y. Leblebici, "Efficient and side-channel-aware implementations of elliptic curve cryptosystems over prime fields," *IET Inform. Security*, vol. 4, no. 1, pp. 30–43, 2010.
- [26] J. Kilian, Ed., *Advances in Cryptology—CRYPTO 2001 (LNCS, vol. 2139)*. New York: Springer-Verlag, 2001.
- [27] N. Kobitz, "Elliptic curve cryptosystems," *Math. Comput.*, vol. 48, no. 177, pp. 203–209, Jan. 1987.
- [28] Ç. K. Koç and T. Acar, "Montgomery multiplication in GF (2^k)," *Des., Codes Cryptogr.*, vol. 14, no. 1, pp. 57–69, Apr. 1998.
- [29] Ç. K. Koç, T. Acar, and B. S. Kaliski, Jr., "Analyzing and comparing Montgomery multiplication algorithms," *IEEE Micro*, vol. 16, no. 3, pp. 26–33, June 1996.
- [30] P. C. Kocher, "Timing attacks on implementations of Diffie-Hellman, RSA, DSS, and other systems," in *CRYPTO (LNCS, vol. 1109)*, N. Kobitz, Ed. New York: Springer-Verlag, 1996, pp. 104–113.
- [31] P. C. Kocher, J. Jaffe, and B. Jun, "Differential power analysis," in *CRYPTO (LNCS, vol. 1666)*, M. J. Wiener, Ed. New York: Springer-Verlag, 1999, pp. 388–397.
- [32] G. Kömürçü and E. Savaş, "An efficient hardware implementation of the Tate pairing in characteristic three," in *ICONS. IEEE Computer Society*, 2008, pp. 23–28. [33] A. J. Menezes, *Elliptic Curve Public Key Cryptosystems*. Norwell, MA: Kluwer, 1993.
- [34] V. S. Miller, "Use of elliptic curves in cryptography," in *CRYPTO (LNCS, vol. 218)*, H. C. Williams, Ed. New York: Springer-Verlag, 1985, pp. 417–426.
- [35] P. L. Montgomery, "Modular multiplication without trial division," *Math. Comput.*, vol. 44, no. 170, pp. 519–521, Apr. 1985.
- [36] National Institute for Standards and Technology, "Digital signature standard (DSS)," *Fed. Reg.*, vol. 56, p. 169, Aug. 1991.
- [37] J.-H. Oh and S.-J. Moon, "Modular multiplication method," *IEE Proc. Comput. Digital Tech.*, vol. 145, no. 4, pp. 317–318, July 1998.
- [38] E. Öksüzoglu and E. Savaş, "Parametric, secure and compact implementation of RSA on FPGA," in *RECONFIG '08: Proc. 2008 Int. Conf. Reconfigurable Computing and FPGAs*. Washington, DC: IEEE Computer Society, 2008, pp. 391–396.
- [39] E. Öztürk, B. Sunar, and E. Savaş, "A versatile Montgomery multiplier architecture with characteristic three support," *Comput. Electr. Eng.*, vol. 35, no. 1, pp. 71–85, 2009.
- [40] E. Öztürk, B. Sunar, and E. Savaş, "Low-power elliptic curve cryptography using scaled modular arithmetic," in *CHES (LNCS, vol. 3156)*, M. Joye and J.-J. Quisquater, Eds. New York: Springer-Verlag, 2004, pp. 92–106.
- [41] R. L. Rivest, A. Shamir, and L. M. Adleman, "A method for obtaining digital signatures and public-key cryptosystems," *Commun. ACM*, vol. 21, no. 2, pp. 120–126, 1978.
- [42] R. Sakai, K. Ohgishi, and M. Kasahara, "Cryptosystems based on pairing," in *Proc. Symp. Cryptography and Information Security*, Okinawa, Japan, Jan. 2000, pp. 26–28.
- [43] E. Savaş and Ç. K. Koç, "Architectures for unified field inversion with applications in proc. vol. 3," in *Proc. 9th IEEE Int. Conf. Electronics, Circuits and Systems—ICECS 2002*, Sept. 2002, pp. 1155–1158.
- [44] E. Savaş and Ç. K. Koç, "The Montgomery modular inverse—revisited," *IEEE Trans. Comput.*, vol. 49, no. 7, pp. 763–766, July 2000.
- [45] E. Savaş, M. Naseer, A. A.-A. Gutub, and Ç. K. Koç, "Efficient unified Montgomery inversion with multibit shifting," *IEE Proc. Comput. Digital Tech.*, vol. 152, no. 4, pp. 489–498, July 2005.
- [46] E. Savaş, A. F. Tenca, M. E. Çiftçibasi, and Ç. K. Koç, "Multiplier architectures for GF (p) and GF (2^k)," *IEE Proc. Comput. Digital Tech.*, vol. 151, no. 2, pp. 147–160, Mar. 2004.
- [47] E. Savaş, A. F. Tenca, and Ç. K. Koç, "A scalable and unified multiplier architecture for finite fields GF (p) and GF (2^m)," in *Cryptographic Hardware and Embedded Systems—CHES 2000 (LNCS, vol. 1965)*, Ç. K. Koç and C. Paar, Eds. New York: Springer-Verlag, 2000, pp. 281–296.
- [48] A. Shamir, "Identity-based cryptosystems and signature schemes," in *Proc. CRYPTO*, 1984, pp. 47–53.
- [49] D. Suzuki, "How to maximize the potential of FPGA resources for modular exponentiation," in *CHES (LNCS, vol. 4727)*. New York: Springer-Verlag, 2007, pp. 272–288.
- [50] S. H. Tang, K. S. Tsui, and P. H. W. Leong, "Modular exponentiation using parallel multipliers," in *Proc. 2003 IEEE Int. Conf. Field Programmable Technology (FPT)*, 2003, pp. 52–59.
- [51] A. F. Tenca and Ç. K. Koç, "A scalable architecture for Montgomery multiplication," in *Cryptographic Hardware and Embedded Systems (LNCS, vol. 1717)*, Ç. K. Koç and C. Paar, Eds. New York: Springer-Verlag, 1999, pp. 94–108.
- [52] A. F. Tenca and L. A. Tawalbeh, "An efficient and scalable radix-4 modular multiplier design using recoding techniques," in *Proc. 37th Asilomar Conf. Signals, Systems, and Computers*. Pacific Grove, CA: IEEE Press, Nov. 9–12, 2003, no. 2, pp. 1445–1450.
- [53] A. F. Tenca, G. Todorov, and Ç. K. Koç, "High-radix design of a scalable modular multiplier," in *CHES (LNCS, vol. 2162)*, Ç. K. Koç, D. Naccache, and C. Paar, Eds. New York: Springer-Verlag, 2001, pp. 185–201.
- [54] C. D. Walter, "Faster modular multiplication by operand scaling," in *Advances in Cryptology—CRYPTO'91 (LNCS, No. 576)*, J. Feigenbaum, Ed. New York: Springer-Verlag, 1992, pp. 313–323.
- [55] C. D. Walter, "Montgomery exponentiation needs no final subtractions," *Electron. Lett.*, vol. 35, no. 21, pp. 1831–1832, Oct. 1999.
- [56] Xilinx Inc. *TrustZone technology overview* [Online]. Available: http://www.xilinx.com/support/documentation/data_sheets/ds312.pdf.
- [57] T. Yanik, E. Savaş, and Ç. K. Koç, "Incomplete reduction in modular arithmetic," *IEE Proc. Comput. Digital Tech.*, vol. 149, no. 2, pp. 46–52, Mar. 2002.